



Hydrographic

and Marine Consultants BV

Fatigue in heavy transport

22 September 2010



Hydrographic and Marine Consultants BV
Operetteweg 4 – 1323 VA Almere-Stad
The Netherlands



Contents

- Introduction



Hydrographic and Marine Consultants BV
Operetteweg 4 – 1323 VA Almere-Stad
The Netherlands



FLOAT ON AND FLOAT OFF



ROLL ON AND ROLL OFF



Hydrographic and Marine Consultants BV
Operetteweg 4 – 1323 VA Almere-Stad
The Netherlands



SKID ON AND LIFT-OFF



SKID ON AND LIFT OFF

Stowage plan

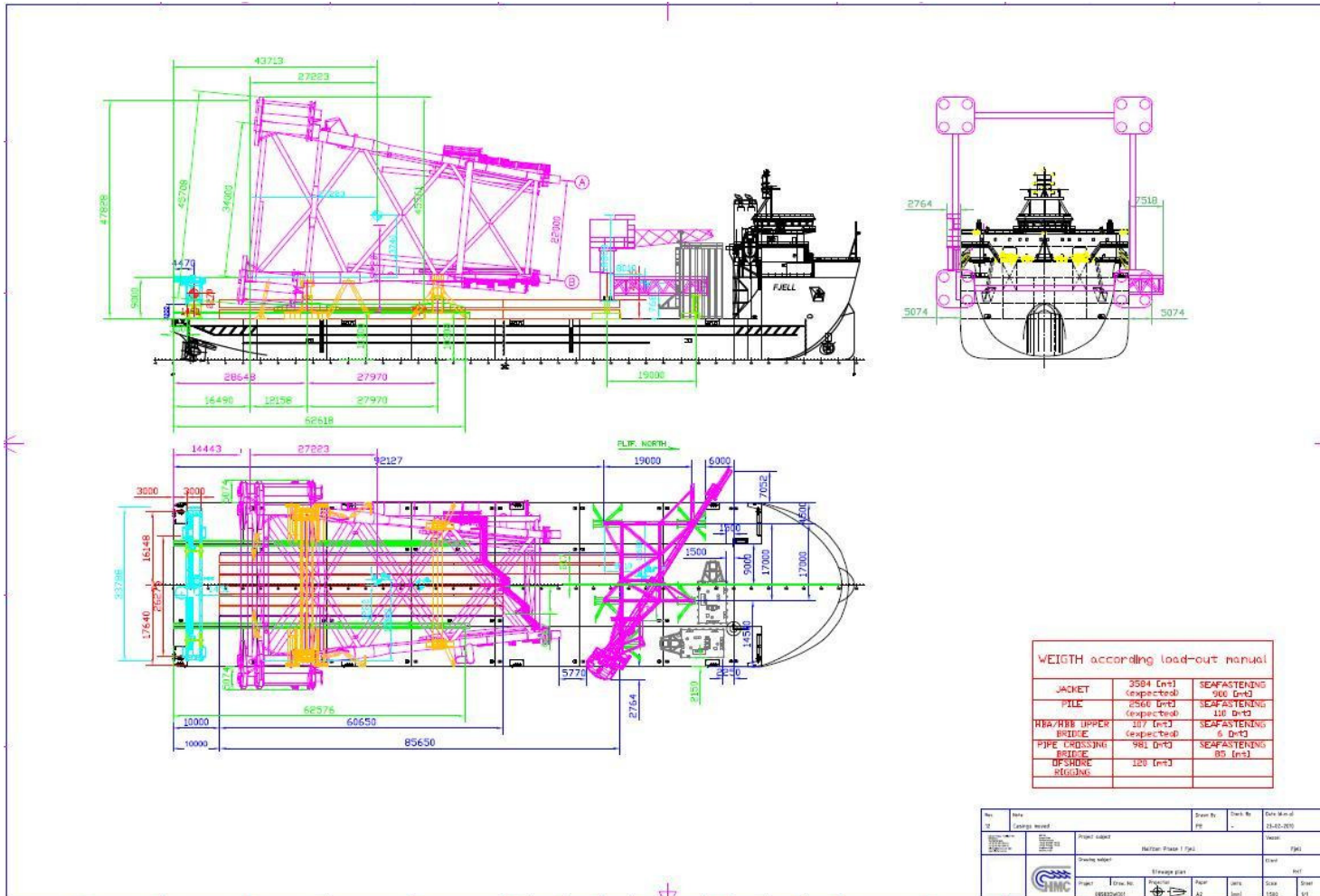

TRANSPORT

Engineering

- MS-TOOL ballast plan calculations
- Ballast plan tidal compensation
- Ballast steps increments/volumes summary skid on
- MS-TOOL calculations for motions
- Mooring analysis
- Finite element calculations for seafastening

SKID ON AND LIFT OFF

Finite element calculations seafastening

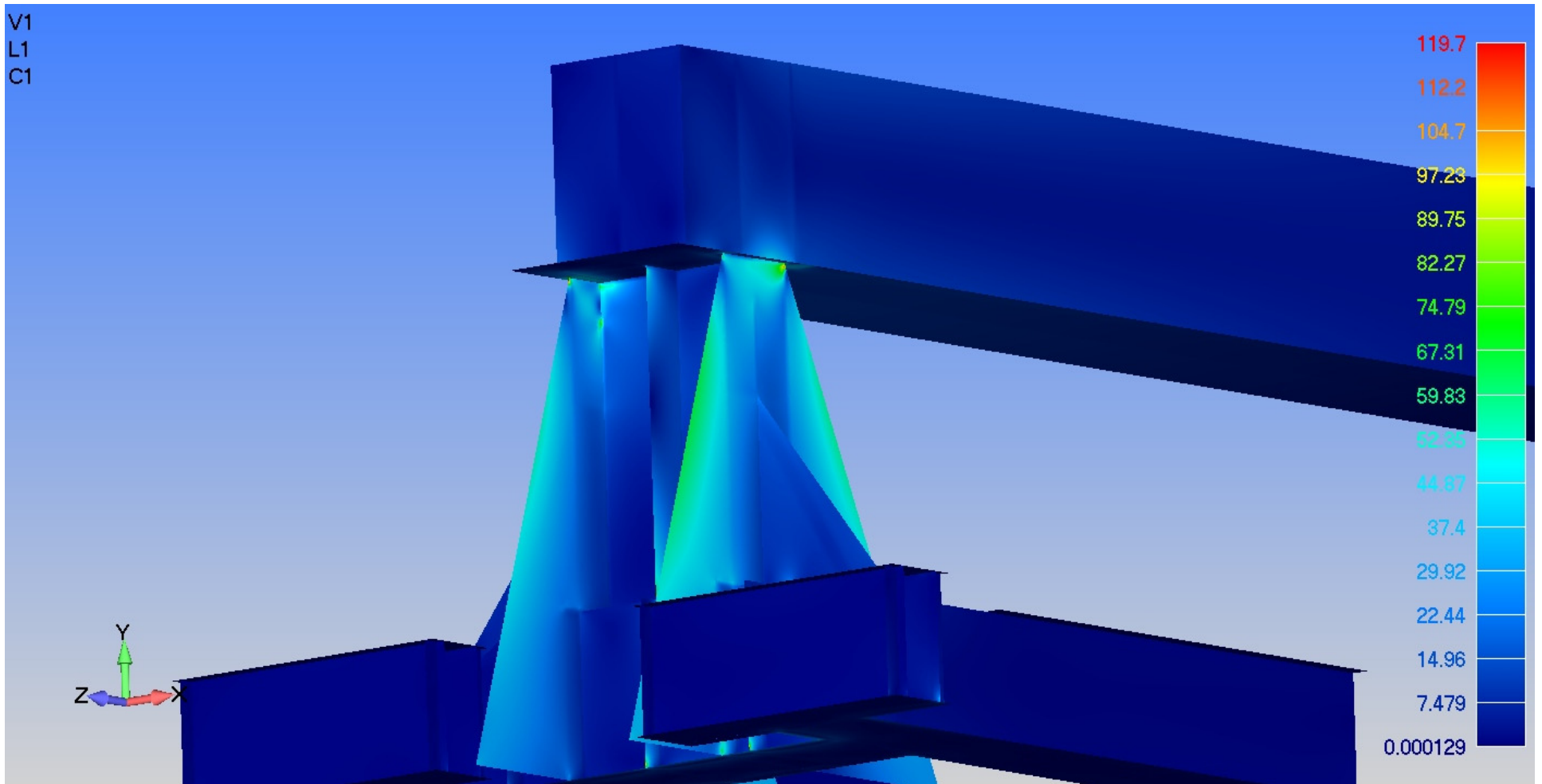

Hydrographic and Marine Consultants BV
Operetteweg 4 – 1323 VA Almere-Stad
The Netherlands



SKID ON AND LIFT OFF

Finite element calculations seafastening

V1
L1
C1

SEAFAST FOR
HBA PIPE CROSSING BRIDGE

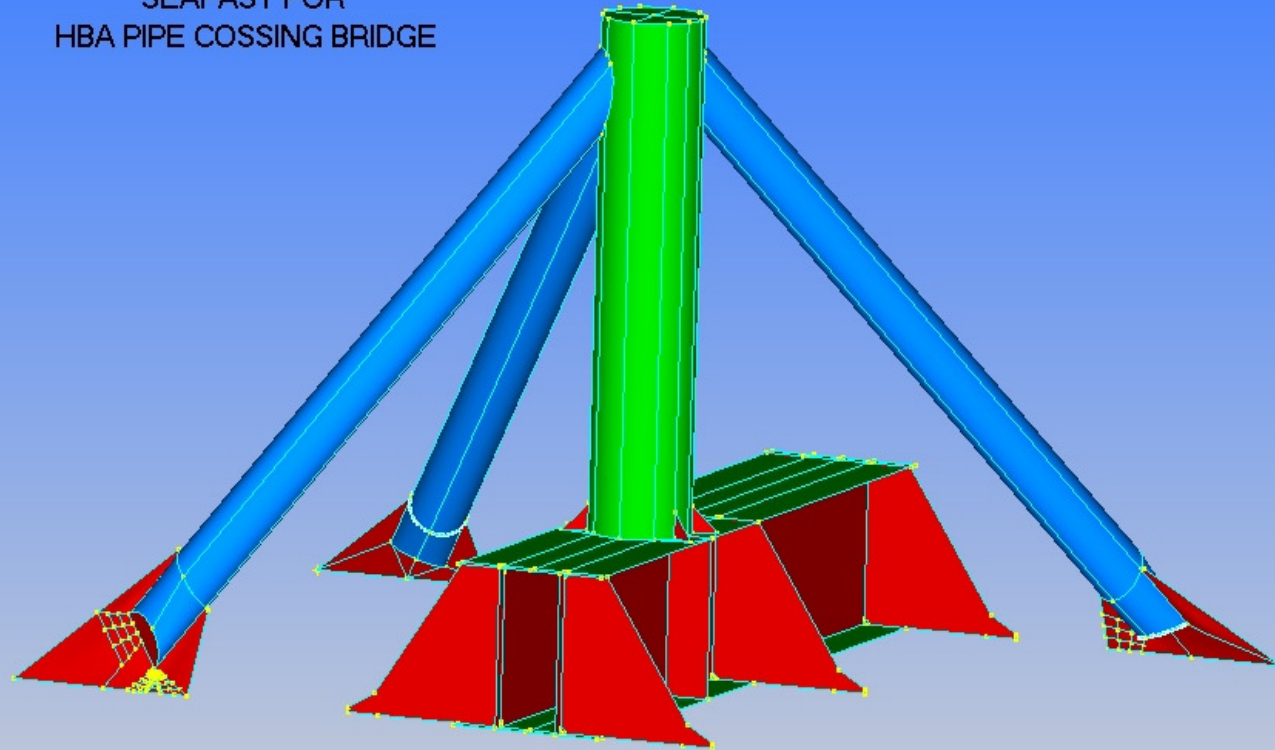

Output Set: NX NASTRAN Case 1
Deformed(0.665): Total Translation



Hydrographic and Marine Consultants BV
Operetteweg 4 – 1323 VA Almere-Stad
The Netherlands



ROLL ON AND ROLL OFF

Finite element calculations seafastening

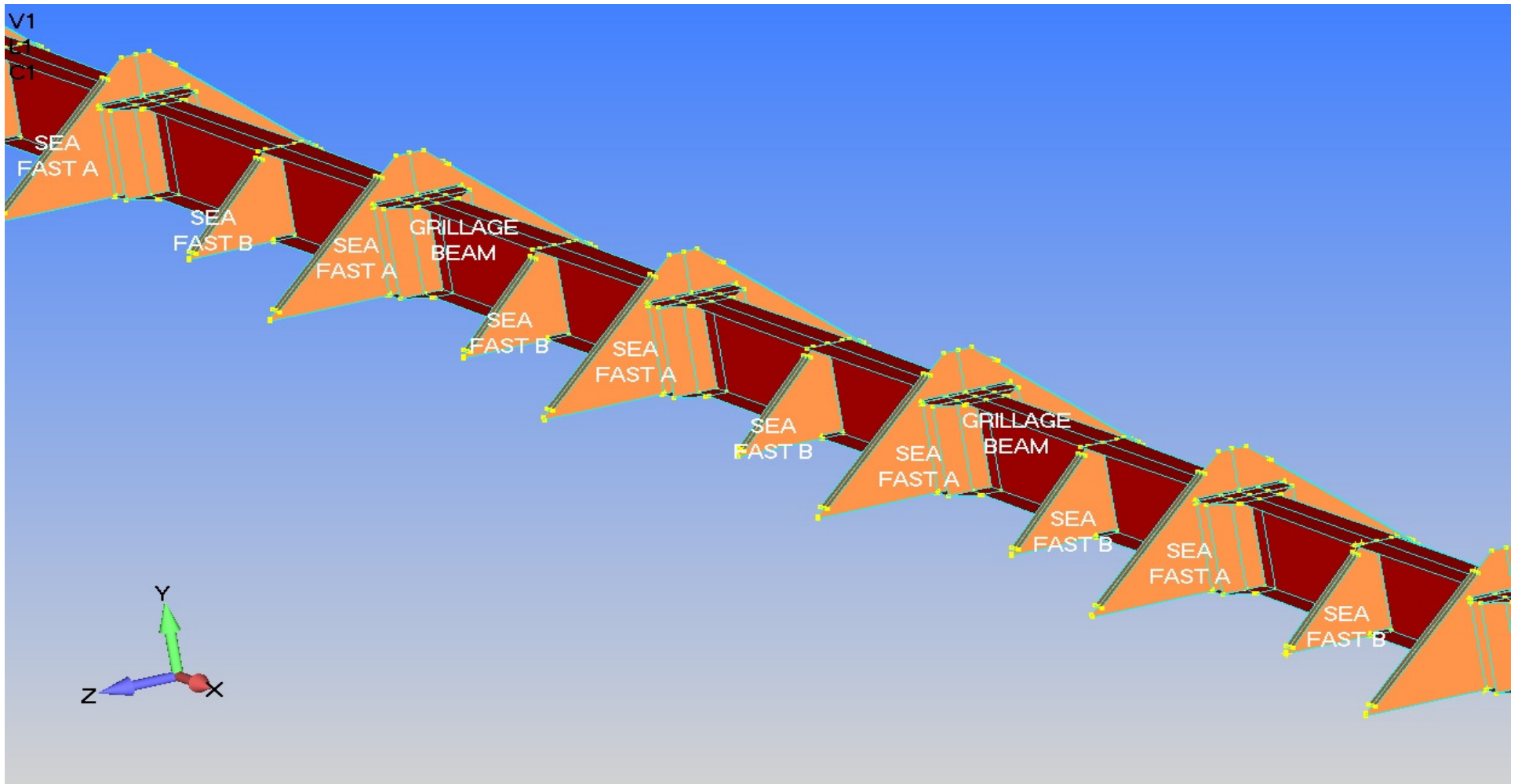

Hydrographic and Marine Consultants BV
Operetteweg 4 – 1323 VA Almere-Stad
The Netherlands



MOG Methodology

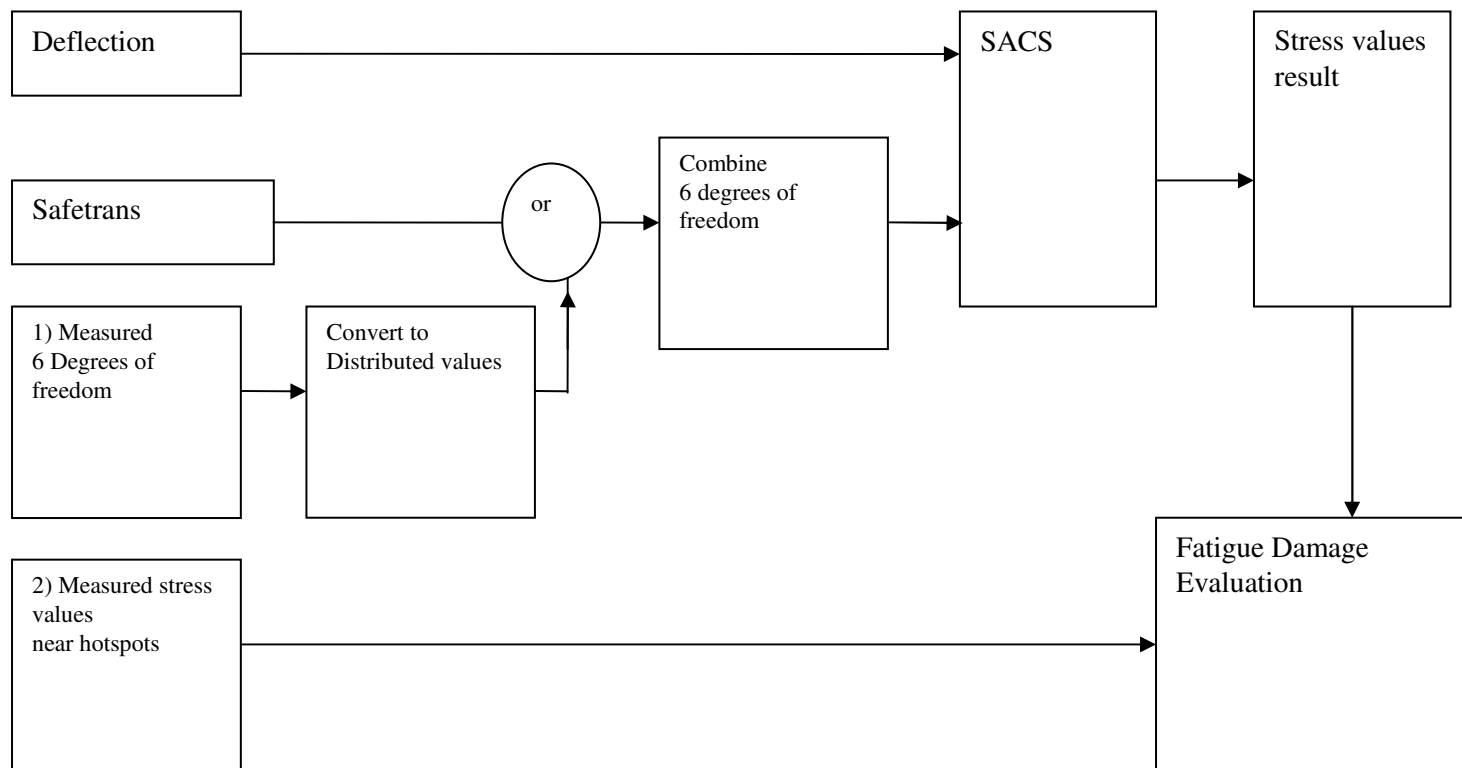

Present methodology in use by plant designers

- 6 degrees of freedom input in SACS for load combinations find the worse case
- Deflection in hogging and sagging for a standard wave
- Maximum values combined.

TOO CONSERVATIVE



Proposed methodology

- SafeTrans for transport simulation and number of oscillations
- Using combined motions
- In the beginning of sailing with self propelled heavy lift ships similar discussion was negotiated for seafastening that combined loads should be used. In fact same counts for fatigue.



Questions



Ton Bos
Hydrographic and Marine Consultants BV
Operetteweg 4 – 1323 VA Almere-Stad
The Netherlands
info@hmc.nl
www.hmc.nl



Hydrographic and Marine Consultants BV
Operetteweg 4 – 1323 VA Almere-Stad
The Netherlands

